

# BP04

## M/C BASE PLATE



- Material: Cast Iron FC300(JIS) / GG30(DIN)
- Heat treated (Normalized)
- Application: Horizontal Machining Center.
- Features: Ready to accept a hole pattern for your special jig.

BP

BPA

BC

CP

SU

PT

SVF

ALV

OK-VISE

OTHER

Column for Technical Data

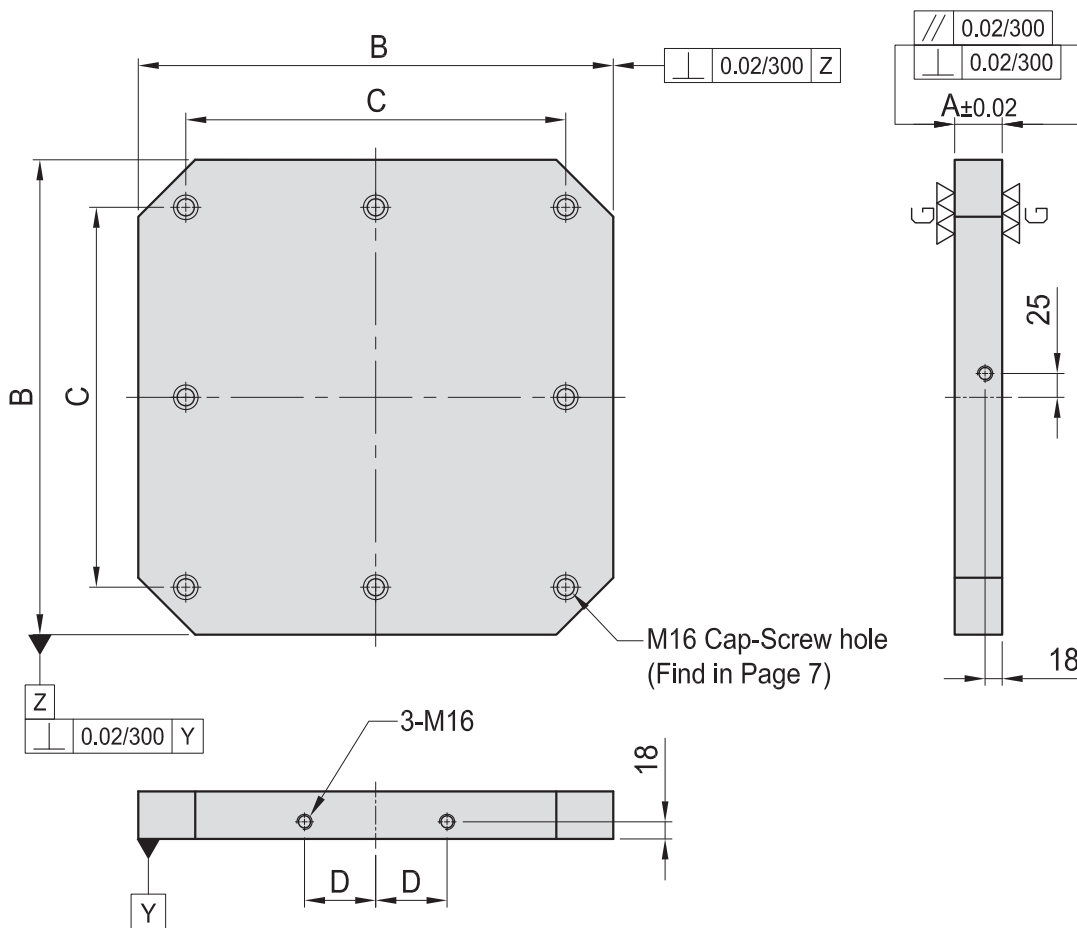

MODEL NO.	A	B	C	D	Mounting holes	kg
BP04-50400-0400	50	400	320	55	4	57
BP04-50500-0500	50	500	400	75	8	88
BP04-50630-0630	50	630	500	100	8	140
BP04-50800-0800	50	800	640	135	8	225

\*Special Design Welcome !