

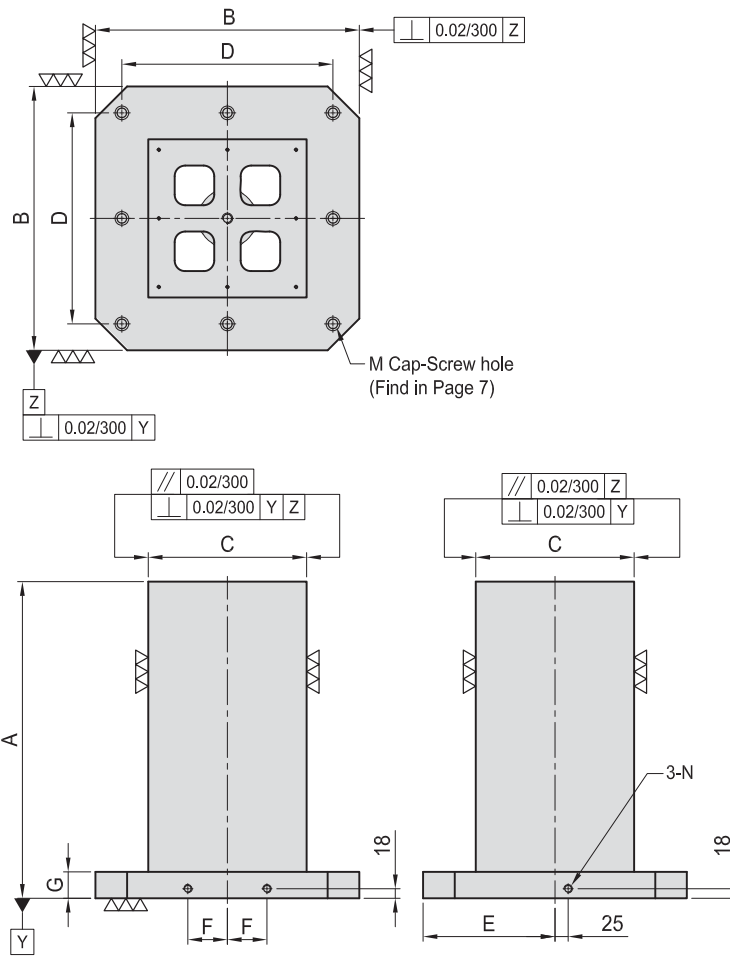

BP07

SQUARE TOOLING COLUMN

- Material: Cast Iron FC300(JIS) / GG30(DIN)
- Heat treated (Normalized)
- Application: Horizontal Machining Center.
- Features: Ready to accept a hole pattern for your special jig.
- Eye bolt & top cover included.



MODEL NO.	A	B	C	D	E	F	G	M	N	Mounting holes	kg
BP07-300300-0500	500	300	150	250	150	40	50	M12	M12	4	90
BP07-400400-0500	500	400	250	320	200	55	50	M16	M16	4	160
BP07-400400-0650	650										210
BP07-500500-0600	600	500	300	400	250	75	50	M16	M16	8	250
BP07-500500-0750	750										310
BP07-630630-0700	700	630	350	500	315	100	50	M16	M16	8	400
BP07-630630-0850	850										460
BP07-800800-0800	800	800	500	640	400	135	50	M16	M16	8	680
BP07-800800-1000	1000										800
BP07-10001000-1000	1000	1000	600	800	500	165	55	M20	M16	8	1164
BP07-10001000-1250	1250										1391

*Special Design Welcome !



BPA07

SQUARE TOOLING COLUMN

- Material: High Strength Aluminum Casting.
- Application: Horizontal Machining Center.
- Features: Ready to accept a hole pattern for your special jig.
- Eye bolt & Top cover included.

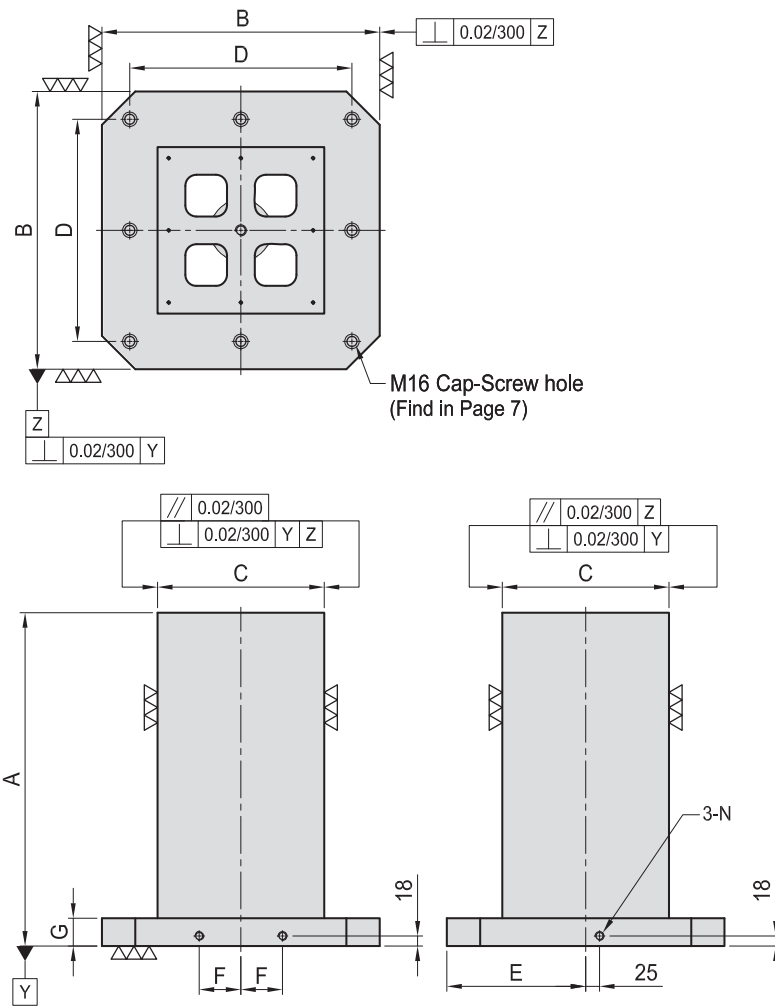

MODEL NO.	A	B	C	D	E	F	G	Mounting holes	kg
BPA07-400400-0500	500	400	250	320	200	55	40	4	56
BPA07-400400-0650	650								73
BPA07-500500-0600	600	500	300	400	250	75	40	8	91
BPA07-500500-0750	750								122
BPA07-630630-0700	700	630	350	500	315	100	50	8	129
BPA07-630630-0850	850								180
BPA07-800800-0800	800	800	500	640	400	135	50	8	215
BPA07-800800-1000	1000								312

*Special Design Welcome !