

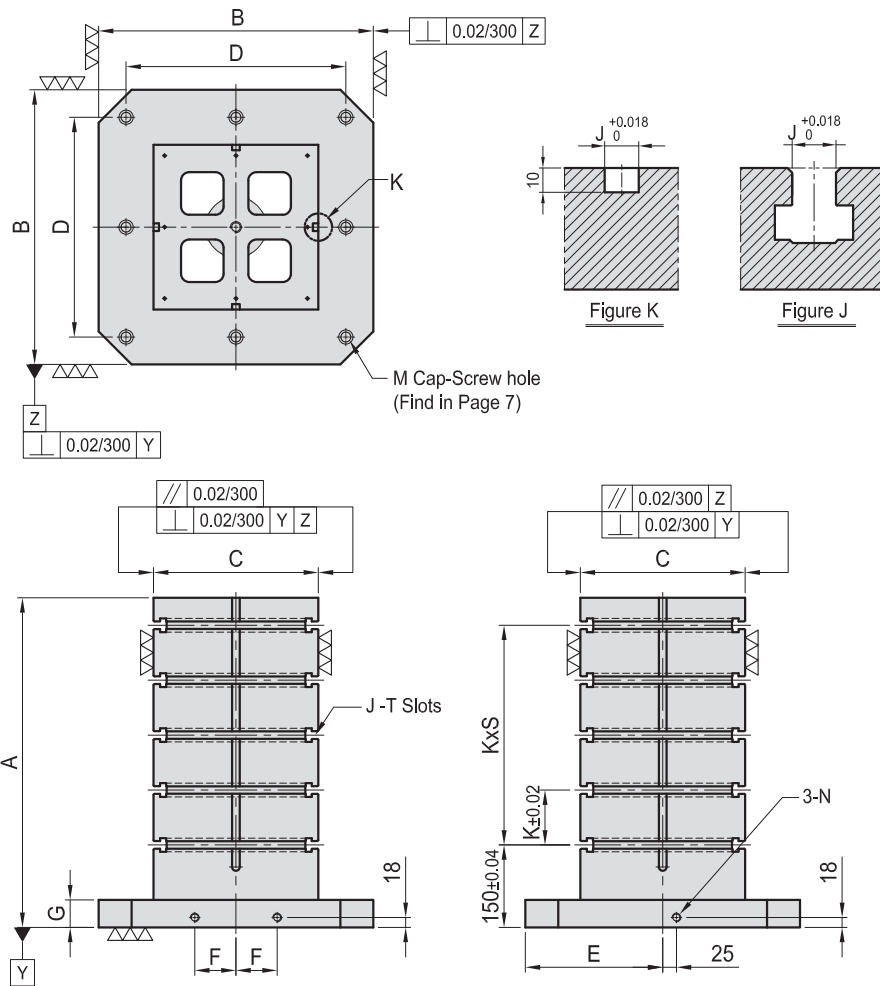

BP09

SQUARE TOOLING COLUMN

- Material: Cast Iron FC300(JIS) / GG30(DIN)
- Heat treated (Normalized)
- Application: Horizontal Machining Center.
- Features: T-Slots running horizontally, key-way running vertically, easily adapts to standardized jig components.
- Eye bolt & top cover included.



MODEL NO.	A	B	C	D	E	F	G	M	N	K	S	J	Mounting holes	kg	MODEL NO.	A	B	C	D	E	F	G	M	N	K	S	J	Mounting holes	kg
BP09-400400-0500-14	500	400	250	320	200	55	50	M16	M16	100	3	14	4	160	BP09-400400-0500-18	500	400	250	320	200	55	50	M16	M16	100	3	18	4	155
BP09-400400-0650-14	650														BP09-400400-0650-18	650													
BP09-500500-0600-14	600	500	300	400	250	75	50	M16	M16	100	4	14	8	270	BP09-500500-0600-18	600	500	300	400	250	75	50	M16	M16	100	4	18	8	265
BP09-500500-0750-14	750														BP09-500500-0750-18	750													
BP09-630630-0700-14	700	630	350	500	315	100	50	M16	M16	125	4	14	8	375	BP09-630630-0700-18	700	630	350	500	315	100	50	M16	M16	125	4	18	8	365
BP09-630630-0850-14	850														BP09-630630-0850-18	850													
BP09-800800-0800-14	800	800	500	640	400	135	50	M16	M16	150	4	14	8	655	BP09-800800-0800-18	800	800	500	640	400	135	50	M16	M16	150	4	18	8	638
BP09-800800-1000-14	1000														BP09-800800-1000-18	1000													
BP09-10001000-1000-14	1000	1000	600	800	500	165	55	M20	M16	160	5	14	8	1146	BP09-10001000-1000-18	1000	1000	600	800	500	165	55	M20	M16	160	5	18	8	1146
BP09-10001000-1250-14	1250														BP09-10001000-1250-18	1250													

*Special Design Welcome !



BPA09

SQUARE TOOLING COLUMN

- Material: High Strength Aluminum Casting.
- Application: Horizontal Machining Center.
- Features: T-Slots running horizontally, key-way running vertically, easily adapts to standardized jig components.
- Eye bolt & Top cover included.

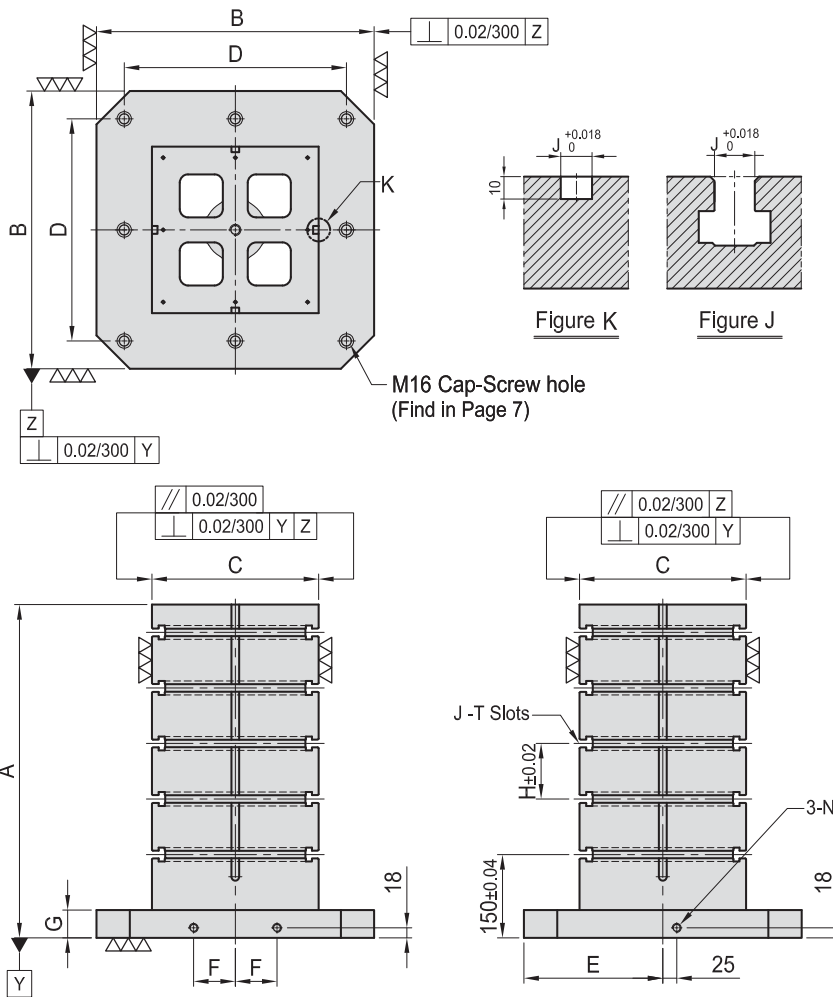

MODEL NO.	A	B	C	D	E	F	G	H	J	Mounting holes	kg	MODEL NO.	A	B	C	D	E	F	G	H	J	Mounting holes	kg
BPA09-400400-0500-14	500	400	250	320	200	55	40	100	14	4	61	BPA09-400400-0500-18	500	400	250	320	200	55	40	100	18	4	60
BPA09-400400-0650-14	650											BPA09-400400-0650-18	650										
BPA09-500500-0600-14	600	500	300	400	250	75	40	100	14	8	86	BPA09-500500-0600-18	600	500	300	400	250	75	40	100	18	8	85
BPA09-500500-0750-14	750											BPA09-500500-0750-18	750										
BPA09-630630-0700-14	700	630	350	500	315	100	50	125	14	8	136	BPA09-630630-0700-18	700	630	350	500	315	100	50	125	18	8	135
BPA09-630630-0850-14	850											BPA09-630630-0850-18	850										
BPA09-800800-0800-14	800	800	500	640	400	135	50	150	14	8	260	BPA09-800800-0800-18	800	800	500	640	400	135	50	150	18	8	254
BPA09-800800-1000-14	1000											BPA09-800800-1000-18	1000										

*Special Design Welcome !