

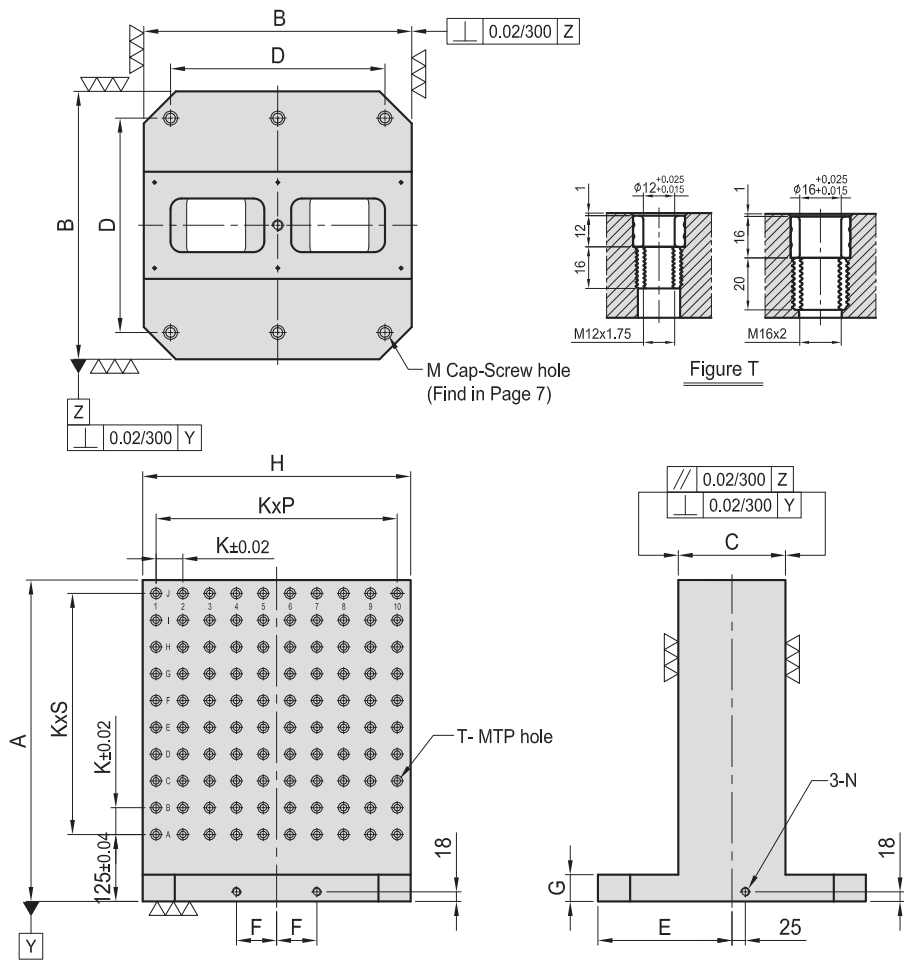

BP11

DOUBLE SIDED TOOLING COLUMN

- Material: Cast Iron FC300(JIS) / GG30(DIN)
- Heat treated (Normalized)
- Alignment Bushing: SUJ2(JIS) / 100Cr6 (DIN), heat treated
- Threaded Insert: S45C(JIS) / CK45(DIN), heat treated
- MTP hole spacing: 50 ± 0.02
- Application: Horizontal Machining Center.
- Features: Alignment bushing & thread insert at every hole location, easily adapts to standardized jig components.
- Eye bolt & top cover included.



MODEL NO.	A	B	C	D	E	F	G	H	K	P	S	T	M	N	MTP	Mounting holes	kg	MODEL NO.	A	B	C	D	E	F	G	H	K	P	S	T	M	N	MTP	Mounting holes	kg		
BP11-300300-0500-12	500	300	80	250	150	40	50	300	50	5	7	Ø12	M12	M12	M12	96	4	110	BP11-300300-0500-16	500	300	80	250	150	40	50	300	50	5	7	Ø16	M16	M12	M12	96	4	105
BP11-400400-0500-12	500	400	150	320	200	55	50	400	50	7	7	Ø12	M12	M16	M16	128	4	165	BP11-400400-0500-16	500	400	150	320	200	55	50	400	50	7	7	Ø16	M16	M16	M16	128	4	160
BP11-400400-0650-12	650										10					176		210	BP11-400400-0650-16	650														176		205	
BP11-500500-0600-12	600	500	200	400	250	75	50	500	50	9	9	Ø12	M12	M16	M16	200	6	265	BP11-500500-0600-16	600	500	200	400	250	75	50	500	50	9	9	Ø16	M16	M16	M16	200	6	260
BP11-500500-0750-12	750										12					260		335	BP11-500500-0750-16	750													260		330		
BP11-630630-0700-12	700	630	250	500	315	100	50	630	50	11	11	Ø12	M12	M16	M16	288	6	435	BP11-630630-0700-16	700	630	250	500	315	100	50	630	50	11	11	Ø16	M16	M16	M16	288	6	430
BP11-630630-0850-12	850										14					360		515	BP11-630630-0850-16	850													360		505		
BP11-800800-0800-12	800	800	300	640	400	135	50	800	50	14	13	Ø12	M12	M16	M16	420	6	660	BP11-800800-0800-16	800	800	300	640	400	135	50	800	50	14	13	Ø16	M16	M16	M16	420	6	650
BP11-800800-1000-12	1000										17					540		800	BP11-800800-1000-16	1000												540		790			
BP11-10001000-1000-12	1000	1000	350	800	500	165	55	1000	50	18	17	Ø12	M12	M20	M16	684	6	1158	BP11-10001000-1000-16	1000	1000	350	800	500	165	55	1000	50	18	17	Ø16	M16	M20	M16	684	6	1158
BP11-10001000-1250-12	1250										22					874		1375	BP11-10001000-1250-16	1250												874		1375			

*Special Design Welcome !



BPA11

DOUBLE SIDED TOOLING COLUMN

- Material: High Strength Aluminum Casting.
- Alignment Bushing: SUJ2(JIS) / 100Cr6 (DIN), heat treated
- Threaded Insert: S45C(JIS) / CK45(DIN), heat treated
- MTP hole spacing: 50 ± 0.02
- Application: Horizontal Machining Center.
- Features: Alignment bushing & thread insert at every hole location, easily adapts to standardized jig components.
- Eye bolt & Top cover included.

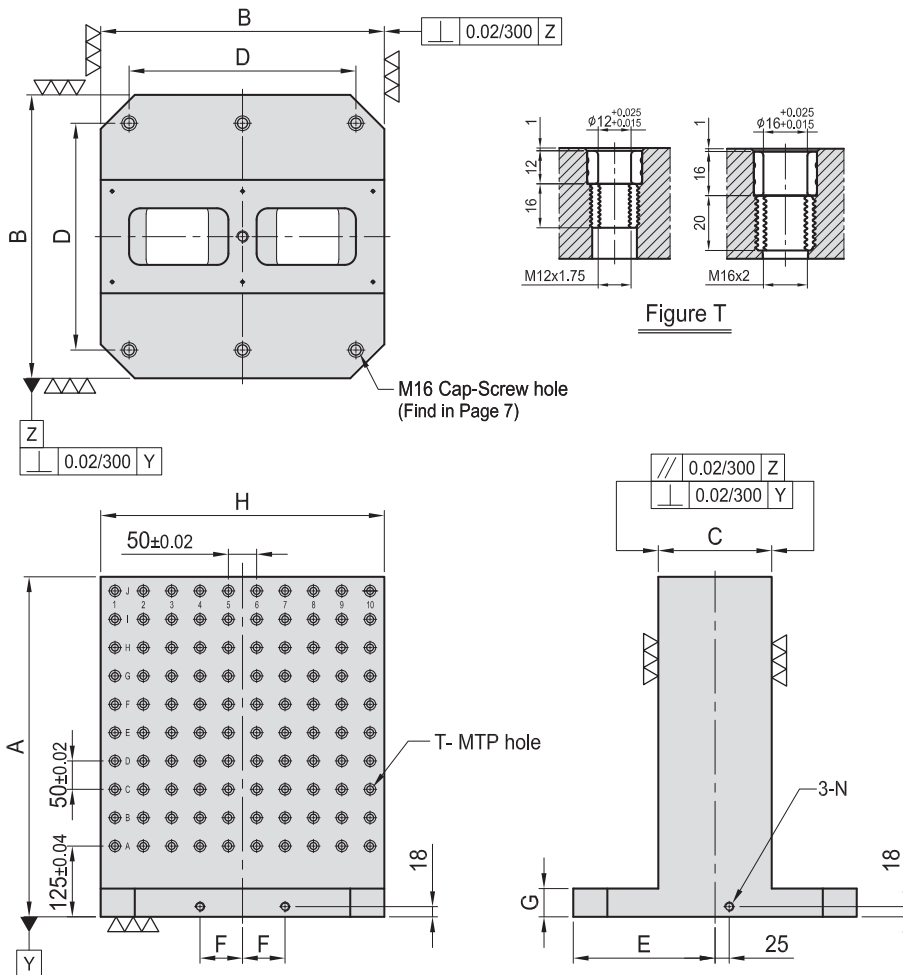

MODEL NO.	A	B	C	D	E	F	G	H	T	MTP	Mounting holes	kg	MODEL NO.	A	B	C	D	E	F	G	H	T	MTP	Mounting holes	kg			
BPA11-400400-0500-12	500	400	150	320	200	55	40	400	$\phi 12$	M12	128	4	56	BPA11-400400-0500-16	500	400	150	320	200	55	40	400	$\phi 16$	M16	128	4	60	
BPA11-400400-0650-12	650										176		86	BPA11-400400-0650-16	650											176		86
BPA11-500500-0600-12	600	500	200	400	250	75	40	500	$\phi 12$	M12	200	6	91	BPA11-500500-0600-16	600	500	200	400	250	75	40	500	$\phi 16$	M16	200	6	103	
BPA11-500500-0750-12	750										260		135	BPA11-500500-0750-16	750											260		135
BPA11-630630-0700-12	700	630	250	500	315	100	50	630	$\phi 12$	M12	288	6	154	BPA11-630630-0700-16	700	630	250	500	315	100	50	630	$\phi 16$	M16	288	6	170	
BPA11-630630-0850-12	850										360		202	BPA11-630630-0850-16	850										360		202	
BPA11-800800-0800-12	800	800	300	640	400	135	50	800	$\phi 12$	M12	420	6	214	BPA11-800800-0800-16	800	800	300	640	400	135	50	800	$\phi 16$	M16	420	6	210	
BPA11-800800-1000-12	1000										540		318	BPA11-800800-1000-16	1000										540		318	

*Special Design Welcome !