

BP21

M/C ANGLE PLATE

- Material: Cast Iron FC300(JIS) / GG30(DIN)
- Heat treated (Normalized)
- Alignment Bushing: SUJ2(JIS) / 100Cr6(DIN), heat treated
- Threaded Insert: S45C(JIS) / CK45(DIN), heat treated
- MTP hole spacing: 50 ± 0.02
- Application: HMC / VMC.
- Features: Alignment bushing & thread insert at every hole location, easily adapts to standardized jig components.

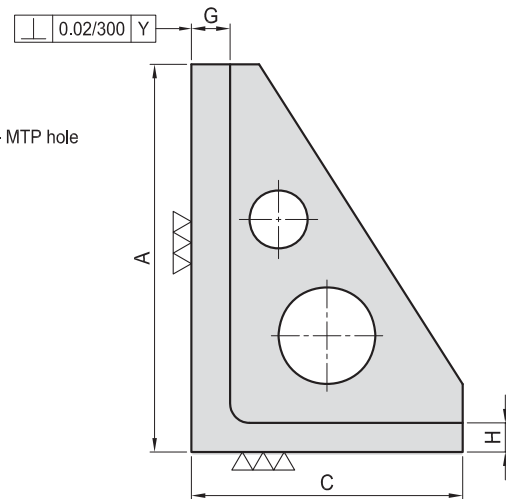
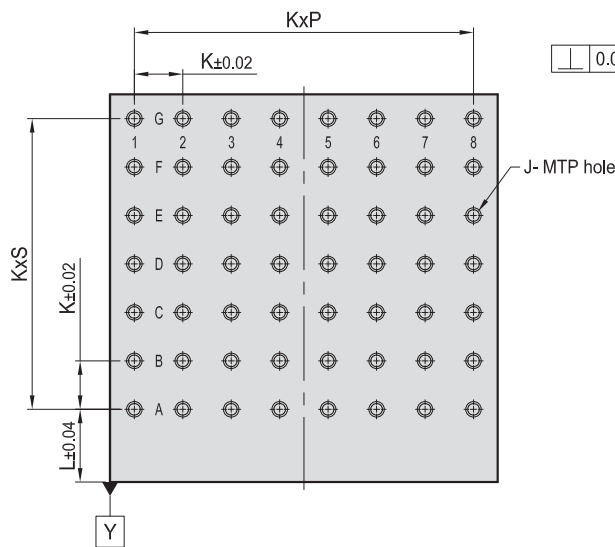
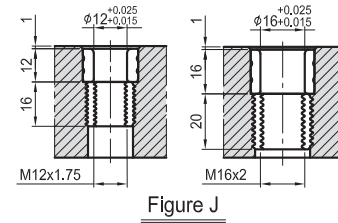
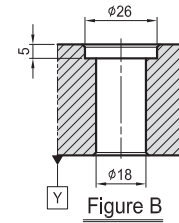
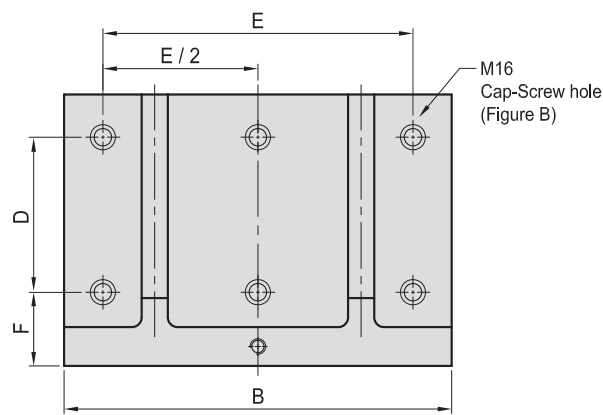

MODEL NO.	A	B	C	D	E	F	G	H	J	K	L	P	S	MTP	Mounting holes	kg	
BP21-220300-0300-12	300	300	220	100	250	90	40	30	$\phi 12$	M12	50	75	5	4	30	6	50
BP21-280400-0400-12	400	400	280	160	320								7	6	56		
BP21-340500-0500-12	500	500	340	200	400	90	50	35	$\phi 12$	M12	50	75	9	8	90	6	173
BP21-435630-0630-12	630	630	435	250	500								100	40	40		
BP21-525800-0800-12	800	800	525	320	640	115	50	45	$\phi 12$	M12	50	75	15	14	240	6	477
BP21-220300-0300-16	300	300	220	100	250	90	40	30	$\phi 16$	M16	50	75	5	4	30	6	46
BP21-280400-0400-16	400	400	280	160	320								7	6	56		
BP21-340500-0500-16	500	500	340	200	400	90	50	35	$\phi 16$	M16	50	75	9	8	90	6	170
BP21-435630-0630-16	630	630	435	250	500								100	40	40		
BP21-525800-0800-16	800	800	525	320	640	115	50	45	$\phi 16$	M16	50	75	15	14	240	6	470

*Special Design Welcome !