



BP22

M/C ANGLE PLATE

- Material: Cast Iron FC300(JIS) / GG30(DIN)
- Heat treated (Normalized)
- Application: HMC / VMC.
- Features: T-Slots running in 2 directions, easily adapts to standardized jig components.

- BP
- BPA
- BC
- CP
- SU
- PT
- SVF
- ALV
- OK-VISE
- OTHER

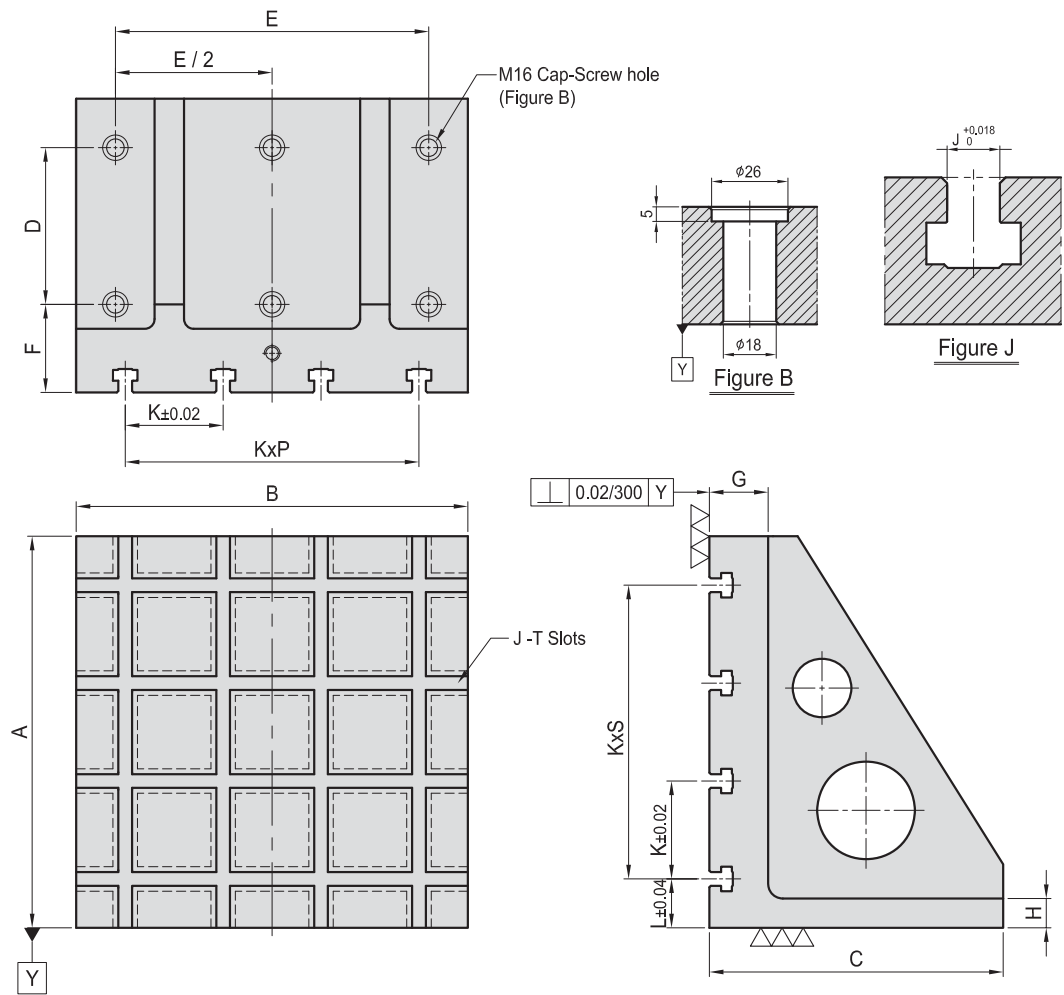

MODEL NO.	A	B	C	D	E	F	G	H	J	K	L	P	S	Mounting holes	kg
BP22-220300-0300-14	300	300	220	100	250	90	60	30	14	100	50	2	2	6	53
BP22-300400-0400-14	400	400	300	160	320							3	3		
BP22-350500-0500-14	500	500	350	200	400	90	60	35	14	100	50	4	4	6	170
BP22-450630-0630-14	630	630	450	250	500										
BP22-550800-0800-14	800	800	550	320	640	115	75	45	14	150	100	4	4	6	566
BP22-220300-0300-18	300	300	220	100	250	90	60	30	18	100	50	2	2	6	51
BP22-300400-0400-18	400	400	300	160	320							3	3		
BP22-350500-0500-18	500	500	350	200	400	90	60	35	18	100	50	4	4	6	162
BP22-450630-0630-18	630	630	450	250	500										
BP22-550800-0800-18	800	800	550	320	640	115	75	45	18	150	100	4	4	6	555

*Special Design Welcome !

Column for Technical Data