

CP20

FORGED SWIVEL CLAMP

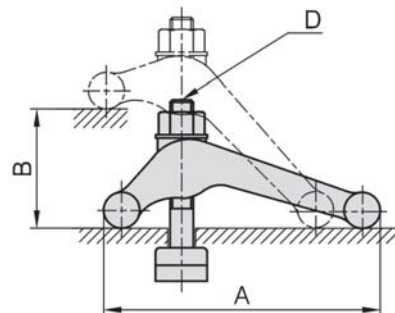

- Material : S45C(JIS), Steel forging.
- Heat treated : HRC 32°~38°.
- Surface finish : Black Oxide.



MODEL NO.	A	B	C	D	kg
CP20-12125	125	75	45	M12-125	1.40
CP20-16150	150	85	52	M16-150	2.42
CP20-20194	194	105	58	M20-175	4.50

SVF

ALV

OK-
VISE

OTHER

Column
for
Technical
Data