

CP12

ADJUSTABLE SIDE CLAMP

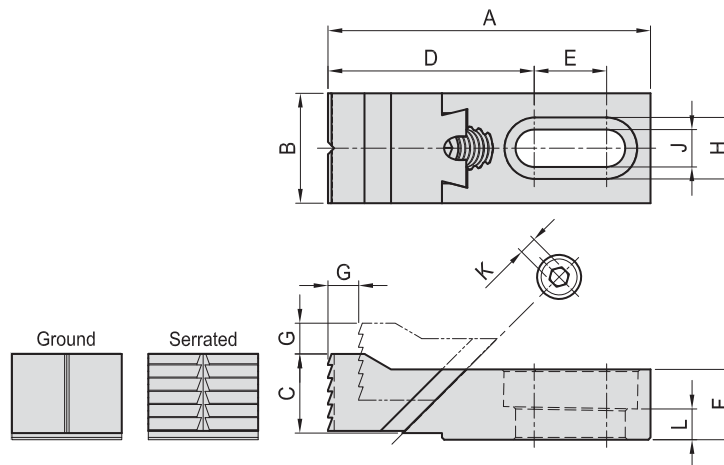

- Material: S45C(JIS) / CK45(DIN)
- Heat treated : HRC 38°. Jaw Surface treated with high frequency quenching.
- Surface finish : Black Oxide.
- Application : Low profile side clamp keeps top surfaces clear for machining, ideal for rough or finished parts, available with plain or serrated jaw.

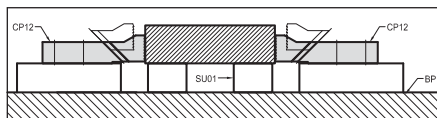

MODEL NO.	A	B	C	D	E	F	G	H	J	K	L	Type	kg
CP12-0825-G	72.0	25	18.0	45.5	16.5	16	7	14	8.5	5	7	Ground	0.18
CP12-1235-G	104.5	35	27.5	62.0	30.0	22	12	20	13.5	6	9		0.52
CP12-1640-G	133.0	40	37.5	80.5	35.0	30	14	26	17.0	8	13		1.02
CP12-0825-S	73.5	25	18.0	47.0	16.5	16	7	14	8.5	5	7	Serrated	0.18
CP12-1235-S	106.5	35	27.5	64.0	30.0	22	12	20	13.5	6	9		0.52
CP12-1640-S	134.5	40	37.5	82.0	35.0	30	14	26	17.0	8	13		1.02

SVF

ALV

OK-
VISE

OTHER

Column
for
Technical
Data