

CP38

ADJUSTABLE SIDE CLAMP

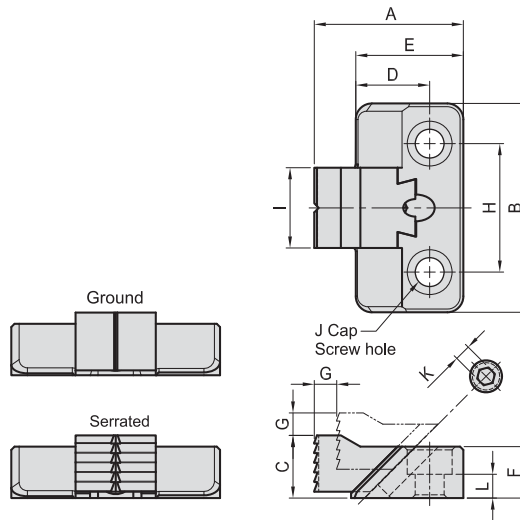

- Material : S45C(JIS) / CK45(DIN)
- Heat treated : HRC 38°. Jaw Surface treated with high frequency quenching.
- Surface finish : Black Oxide.
- Application : Low profile side clamp keeps top surfaces clear for machining, ideal for rough or finished parts, available with plain or serrated jaw.



MODEL NO.	A	B	C	D	E	F	G	H	I	J	K	L	Type	kg
CP38-0865-G	45.14	65	19.5	23	33.5	16	7	40	25	M 8	5	7.4	Ground	0.22
CP38-1285-G	65.14	85	29.0	33	48.0	22	12	50	35	M12	6	9.0		0.65
CP38-16100-G	85.64	100	39.0	48	68.0	30	14	50	40	M16	8	12.5		1.40
CP38-0865-S	46.45	65	19.5	23	33.5	16	7	40	25	M 8	5	7.4	Serrated	0.22
CP38-1285-S	67.14	85	29.0	33	48.0	22	12	50	35	M12	6	9.0		0.65
CP38-16100-S	87.14	100	39.0	48	68.0	30	14	50	40	M16	8	12.5		1.40

SVF

ALV

OK-
WISE

OTHER

Column
for
Technical
Data