

CP39

ADJUSTABLE SIDE CLAMP

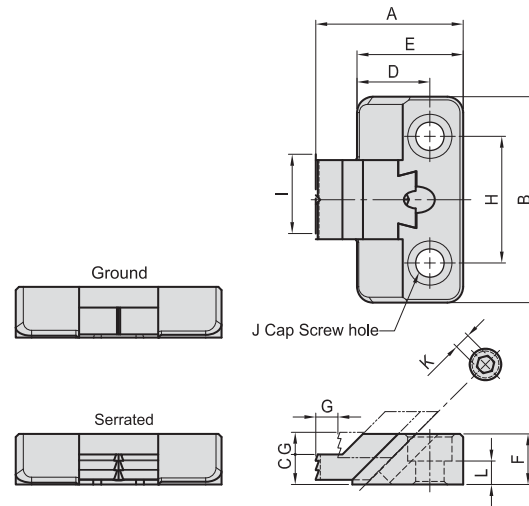

- Material : S45C(JIS) / CK45(DIN)
- Heat treated : HRC 38°. Jaw Surface treated with high frequency quenching.
- Surface finish : Black Oxide.
- Application : Low profile side clamp keeps top surfaces clear for machining, ideal for rough or finished parts, available with plain or serrated jaw.



MODEL NO.	A	B	C	D	E	F	G	H	I	J	K	L	Type	kg
CP39-0865-G	45.14	65	9.5	23	33.5	16	7	40	25	M 8	5	7.4	Ground	0.2
CP39-1285-G	65.64	85	12.0	33	48.0	22	12	50	35	M12	6	9.0		0.6
CP39-16100-G	86.14	100	15.5	48	68.0	30	14	50	40	M16	8	12.5		1.3
CP39-0865-S	46.55	65	9.5	23	33.5	16	7	40	25	M 8	5	7.4	Serrated	0.2
CP39-1285-S	67.14	85	12.0	33	48.0	22	12	50	35	M12	6	9.0		0.6
CP39-16100-S	87.64	100	15.5	48	68.0	30	14	50	40	M16	8	12.5		1.3