

PT05

EXTENSION NUT

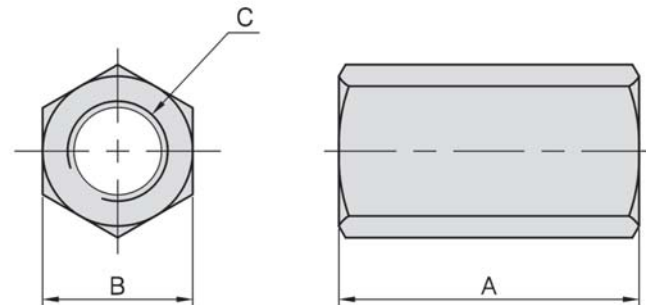

- Material : S45C(JIS) / CK45(DIN)
- Heat treated : HRC 30°~35°.
- Surface finish : Black Oxide.
- Application : Extends the length of clamping studs.

MODEL NO.	A	B	C	kg
PT05-0813	22	14	M 8	0.020
PT05-1017	30	17	M10	0.030
PT05-1219	36	19	M12	0.046
PT05-1422	42	22	M14	0.065
PT05-1624	48	24	M16	0.110
PT05-1827	54	27	M18	0.150
PT05-2030	60	30	M20	0.220
PT05-2232	66	32	M22	0.350
PT05-2436	72	36	M24	0.350