

PT25

SPHERICAL WASHER

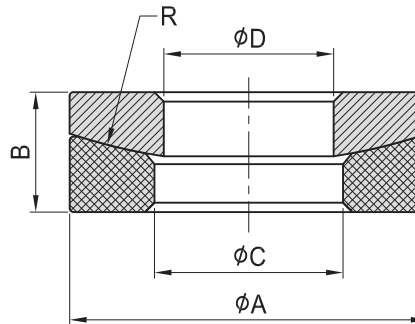

- Material : S45C(JIS)/CK45(DIN)
- Heat treated : HRC 38°
- Surface finish : Black Oxide.
- Application : Two-piece washer that compensates whenever a stud and clamping surface are not exactly perpendicular.

MODEL NO.	A	B	C	D	R	kg
PT25-0819	19	6.2	10	9	30	0.013
PT25-1022	22	8.0	12	11		0.019
PT25-1226	26	7.5	15	13	32	0.024
PT25-1428	28	9.0	16	15		0.033
PT25-1632	32		19	17	40	0.058
PT25-1835	35	10.0	20	19		0.050
PT25-2040	40	11.8	23	21	48	0.089
PT25-2245	45	12.5	26	24		70
PT25-2450	50	13.5	28	27	0.150	

SVF

ALV

OK-
WISE

OTHER

Column
for
Technical
Data