

# PT55

## SPRING LOCATING PINS



### TYPE A

- Body Material : Aluminum  
Surface finish : Silver passivated
- Pin Material : Steel  
Heat treated : HRC 45°  
Surface finish : Galvanized
- Spring Material : Spring steel wire

### TYPE B

- Body Material : Aluminum  
Surface finish : Silver passivated
- Pin Material : Steel  
Heat treated : HRC 45°  
Surface finish : Galvanized
- Spring Material : Spring steel wire
- Seal Material : CR

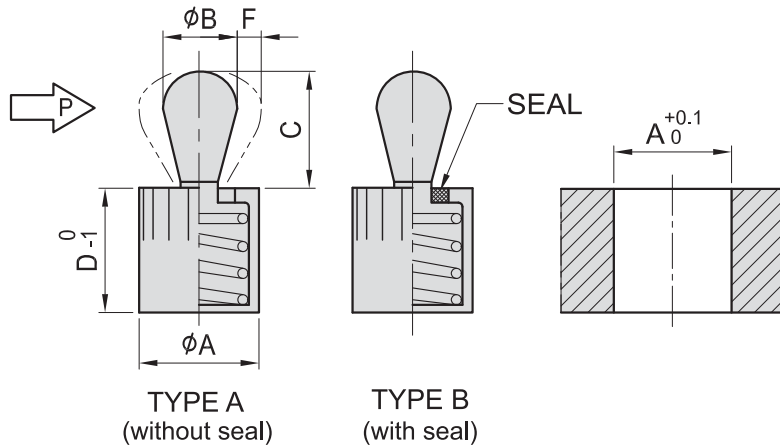

Note :

- P(N) : The MAX Strength when pin moves
- Application temperature with steel pins up to 250°C
- See P.6-34 Installtion method
- See P.6-34 Installtion tool

Example :

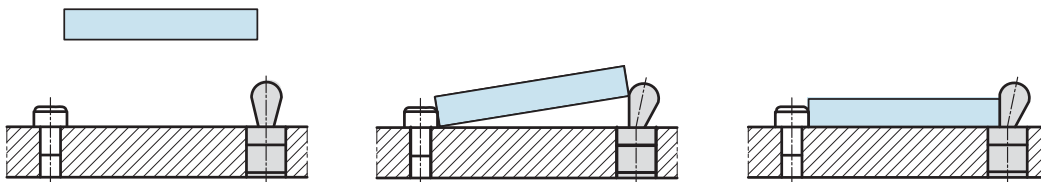

### TYPE A

MODEL NO.	A	B	C	D	F	P(N)	INSTALLATION TOOLS	g
PT55A-0603-010	6	3	4.0	7	0.5	10	PT57-0603	0.6
20						0.6		
40						0.7		
PT55A-1005-020	10	5	6.7	11	0.8	20	PT57-1006	2.7
50						2.8		
100						3.1		
PT55A-1006-040						40		3.4
PT55A-1006-075	6	10.7	11	1.0	75	PT57-1006	3.6	
150					3.8			
PT55A-1208-050	12	8	13.9	13	1.3	50	PT57-1208	6.8
100						7.4		
200						7.4		
PT55A-1610-100	16	10	16.7	17	1.6	100	PT57-1610	15.0
200						15.0		
300						15.3		

### TYPE B

MODEL NO.	A	B	C	D	F	P(N)	INSTALLATION TOOLS	g
PT55B-0603-010	6	3	4	7	0.5	10	PT57-0603	0.6
20						0.6		
40						0.7		
PT55B-1005-020	10	5	6	12	0.8	20	PT57-1006	2.7
50						2.9		
100						3.1		
PT55B-1006-040						40		3.4
PT55B-1006-075	6	10	12	1.0	75	PT57-1006	3.7	
150					3.8			
PT55B-1208-050	12	8	13	14	1.3	50	PT57-1208	7.0
100						7.3		
200						7.4		
PT55B-1610-100	16	10	16	18	1.6	100	PT57-1610	15.0
200						15.2		
300						15.6		

BP

BPA

BC

CP

SU

PT

SVF

ALV

OK-VISE

OTHER

Column for Technical Data