

SVF-BE

FLEXIBLE LINE UP VISE SERIES

Two way clamping

BE series offers more parts held & larger size parts held - compared to the "B" series

- Material 100% tool steel
- Heat treated HRC 55° & ground

**High Capacity
High Flexibility**

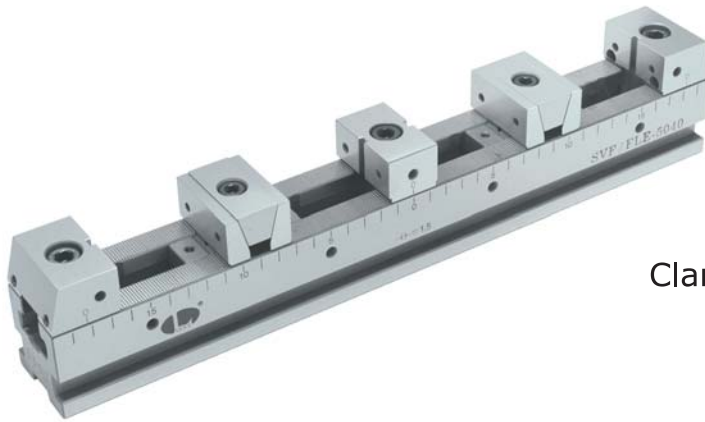

SVF-50 : 1000 kgf
Clamping force: SVF-72 : 2000 kgf
SVF-100: 3000 kgf

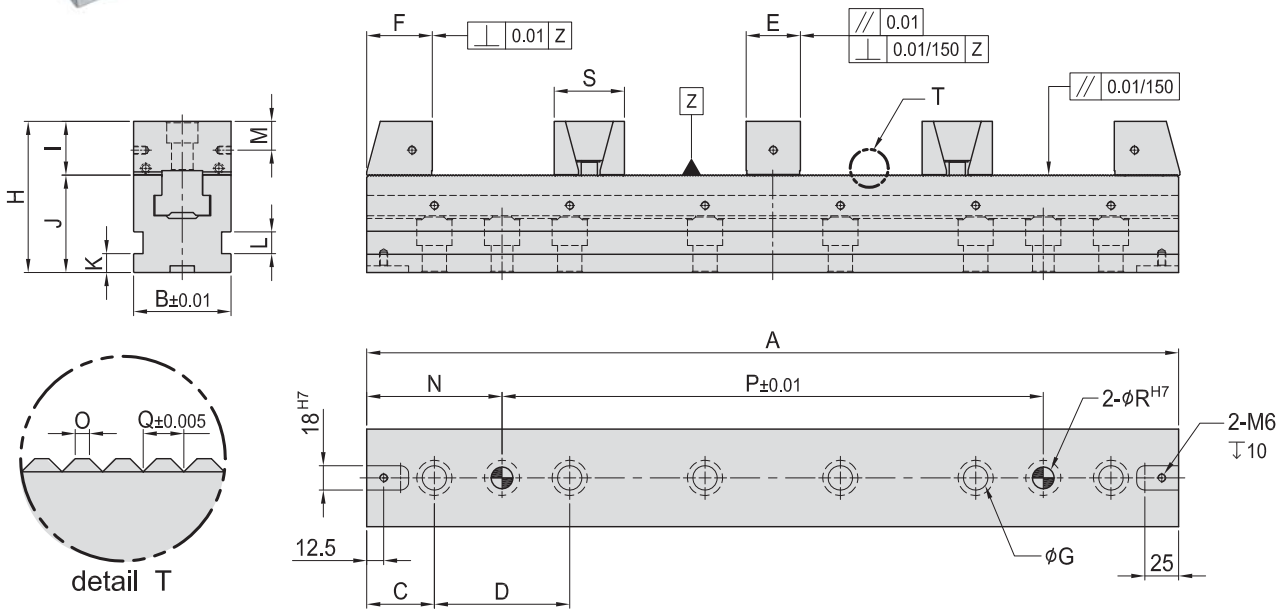

- BP
- BPA
- BC
- CP
- SU
- PT
- SVF**
- ALV
- OK-VISE
- OTHER

MODEL NO.	A	B	C	D	E	F	G	H	I	J	K	L	M	N	O	P	Q	R	S	kg
SVF-BE-5030-80	300	50	30	80	30	36	14	75	24.8	50	10	12	12.5	70	0.50	160	1.5	12	36	6.0
SVF-BE-5030-100			50	100										100		100				
SVF-BE-5040-80	400	50	40	80	30	36	14	75	24.8	50	10	12	12.5	80	0.50	240	1.5	12	36	7.5
SVF-BE-5040-100			50	100										100		200				
SVF-BE-5050-80	500	50	50	80	30	36	14	75	24.8	50	10	12	12.5	90	0.50	320	1.5	12	36	9.0
SVF-BE-5050-100				100										100		300				
SVF-BE-5060-80	600	50	60	80	30	36	14	75	24.8	50	10	12	12.5	100	0.50	400	1.5	12	36	10.2
SVF-BE-5060-100			50	100										100		400				
SVF-BE-5070-80	700	50	70	80	30	36	14	75	24.8	50	10	12	12.5	110	0.50	480	1.5	12	36	11.5
SVF-BE-5070-100			50	100										100		500				
SVF-BE-7240-100	400	72	50	100	40	48	18	112	39.7	72	14	16	21.3	100	0.70	200	2.0	16	52	18.0
SVF-BE-7250-100	500													100		300				21.0
SVF-BE-7260-100	600	72	50	100	40	48	18	112	39.7	72	14	16	21.3	100	0.70	400	2.0	16	52	24.0
SVF-BE-7270-100	700													100		500				26.0
SVF-BE-10040-100	400	100	50	100	44	48	18	115	43.1	72	14	16	22.2	100	0.85	200	2.5	16	65	27.0
SVF-BE-10050-100	500													100		300				31.0
SVF-BE-10060-100	600	100	50	100	44	48	18	115	43.1	72	14	16	22.2	100	0.85	400	2.5	16	65	35.0
SVF-BE-10070-100	700													100		500				39.0

(SVF vises listed above come equipped to clamp 1-4 parts, if additional part clamping is required please order optional accessories as listed on pages 7-14 ~ 7-19)

Column for Technical Data

SVF-BE

SVF-BE

Forcing direction



Maximum width of the workpieces which can be clamped

MODEL NO.	1 pcs	2 pcs	3 pcs	4 pcs	5 pcs
SVF-BE-5030	203	96	45	31	14
SVF-BE-5040	303	146	79	56	34
SVF-BE-5050	403	196	112	81	54
SVF-BE-5060	503	246	145	106	74
SVF-BE-5070	603	296	179	131	94
SVF-BE-7240	269	126	59	40	17
SVF-BE-7250	369	176	92	65	37
SVF-BE-7260	469	226	125	90	57
SVF-BE-7270	569	276	159	115	77
SVF-BE-10040	258	119	49	32	-
SVF-BE-10050	358	169	83	57	28
SVF-BE-10060	458	219	116	82	48
SVF-BE-10070	558	269	149	107	68

MODEL NO.	6 pcs	7 pcs	8 pcs	9 pcs
SVF-BE-5030	--	--	--	--
SVF-BE-5040	26	15	--	--
SVF-BE-5050	43	29	24	15
SVF-BE-5060	60	43	36	26
SVF-BE-5070	76	58	49	37
SVF-BE-7240	--	--	--	--
SVF-BE-7250	28	--	--	--
SVF-BE-7260	44	27	22	--
SVF-BE-7270	61	41	34	22
SVF-BE-10040	--	--	--	--
SVF-BE-10050	19	--	--	--
SVF-BE-10060	36	18	--	--
SVF-BE-10070	53	32	26	--

MODEL NO.	10 pcs	11 pcs	12 pcs	13 pcs
SVF-BE-5030	--	--	--	--
SVF-BE-5040	--	--	--	--
SVF-BE-5050	--	--	--	--
SVF-BE-5060	22	15	--	--
SVF-BE-5070	32	24	21	16
SVF-BE-7240	--	--	--	--
SVF-BE-7250	--	--	--	--
SVF-BE-7260	--	--	--	--
SVF-BE-7270	18	--	--	--
SVF-BE-10040	--	--	--	--
SVF-BE-10050	--	--	--	--
SVF-BE-10060	--	--	--	--
SVF-BE-10070	--	--	--	--

BP

BPA

BC

CP

SU

PT

SVF

ALV

OK-
VISE

OTHER

Column
for
Technical
Data