

# ALV

## HIGH STRENGTH ALUMINUM LINE UP VISE

- Material: High strength aluminum A7075 (Hard coat surface)  
Tool steel (Hardness: over HRC 55°)
- Application: Ideal for aluminum or irregular shaped work pieces.

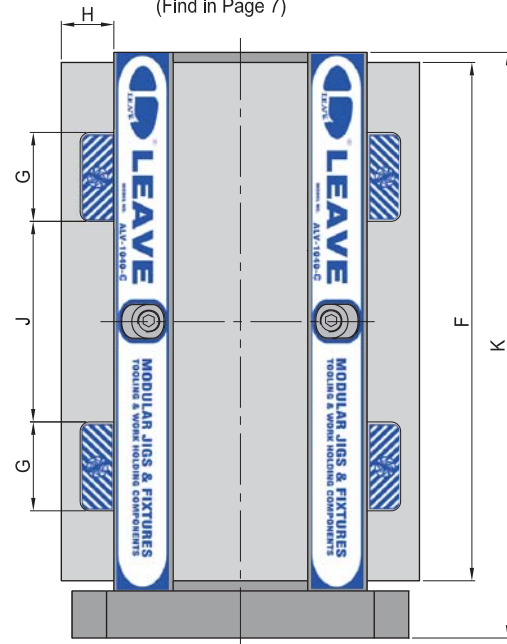
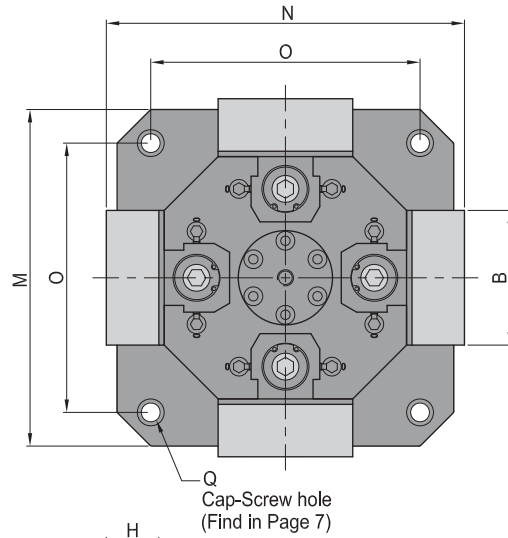

BP

BPA

BC

CP

SU

PT

SVF

**ALV**

OK-VISE

OTHER

Column for Technical Data

MODEL NO.	B	F	G	H	J	K	M	N	O	Q	kg
ALV-1030-C-0	100	299	66	45	104.0	335	250	278	200	M12	47.00
ALV-1030-C-0H				54				296			50.00
ALV-1030-C-0W	150	299	66	45	104.0	335	250	278	200	M12	54.40
ALV-1030-C-0WH				54				296			58.80
ALV-1040-C-0	100	399	66	45	149.0	435	250	278	200	M12	60.70
ALV-1040-C-0H				54				296			64.38
ALV-1040-C-0W	150	399	66	45	149.0	435	250	278	200	M12	69.22
ALV-1040-C-0WH				54				296			71.90
ALV-1550-C-0	150	499	89	49	198.5	545	300	338	250	M16	127.00
ALV-1550-C-0H				59				358			138.20
ALV-1550-C-0W	200	499	89	49	198.5	545	300	338	250	M16	145.40
ALV-1550-C-0WH				59				358			154.20

\*ALL SIZE BASE PLATES ARE AVAILABLE FOR THE ALV VISE.