

# MCA

## SUPER THIN SQUARE CHUCKS

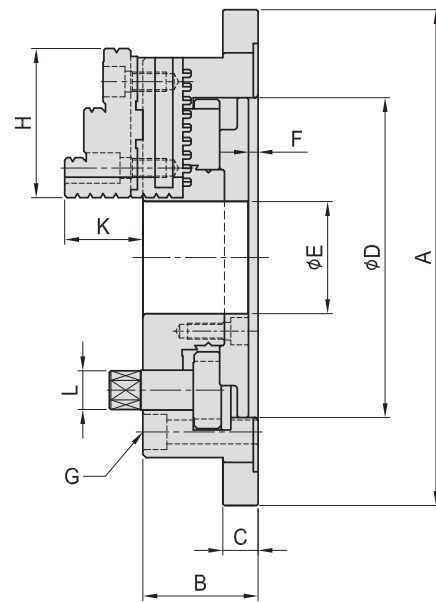

- MC chucks are precisely ground, the tolerances of W,X,Y,Z among chucks are within 0.05mm.
- Soft jaws can be used alternatively for machining special shaped work pieces, to substitute for designing and making a lot of jigs for this purpose.
- The repetitive gripping accuracy with the hard jaws are within 0.02mm.
- Parallel gripping accuracy with hard jaws can be controlled within 0.05mm after aligning sides of chucks.

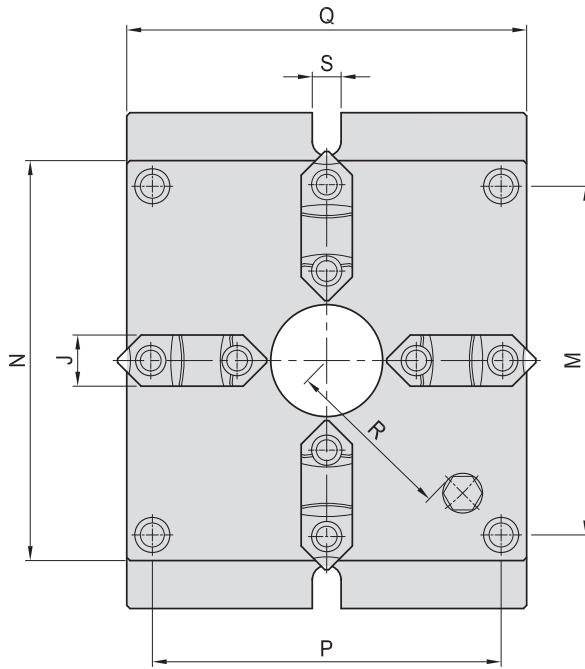

SPEC./MODEL	A	B	C	D	E	F	G	H	J	K	L	M	N	P	Q	R	S	Max. Dia Gripped by		kg
																		external	internal	
MCA-06	215	57	18	130	40	5.5	4-M10	68	26	39	14	144	165	144	165	66	18	φ4-φ128	φ55-φ128	11.4
MCA-08	250	65	20	160	55	6.0	4-M12	82	28	43	17	174	200	174	200	83	18	φ5-φ162	φ62-φ162	18.6
MCA-10	310	72	22	200	70	6.0	4-M14	93	32	50	21	218	250	218	250	104	18	φ6-φ200	φ72-φ200	31.6
MCA-12	380	85	25	260	100	7.0	4-M16	117	40	56	23	274	310	274	310	135	22	φ10-φ265	φ90-φ265	56.6