

# PT30

## LIFTING EYEBOLT

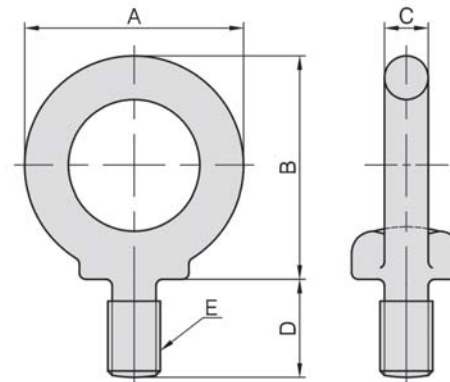

MODEL NO.	A	B	C	D	E	Load kg	kg
PT30-08	32.6	33.3	6.3	15	M 8	80	0.032
PT30-10	41.0	41.5	8.0	18	M10	150	0.063
PT30-12	50.0	51.0	10.0	22	M12	220	0.125
PT30-16	60.0	60.0	12.5	27	M16	450	0.216
PT30-20	72.0	71.0	16.0	30	M20	630	0.400
PT30-24	90.0	90.0	20.0	38	M24	950	0.830
PT30-30	110.0	110.0	25.0	45	M30	1500	1.500
PT30-36	133.0	131.5	31.5	55	M36	2300	2.900
PT30-42	151.0	150.5	35.5	65	M42	3400	4.400