

6-M16
Cap-Screw hole
(Figure A)

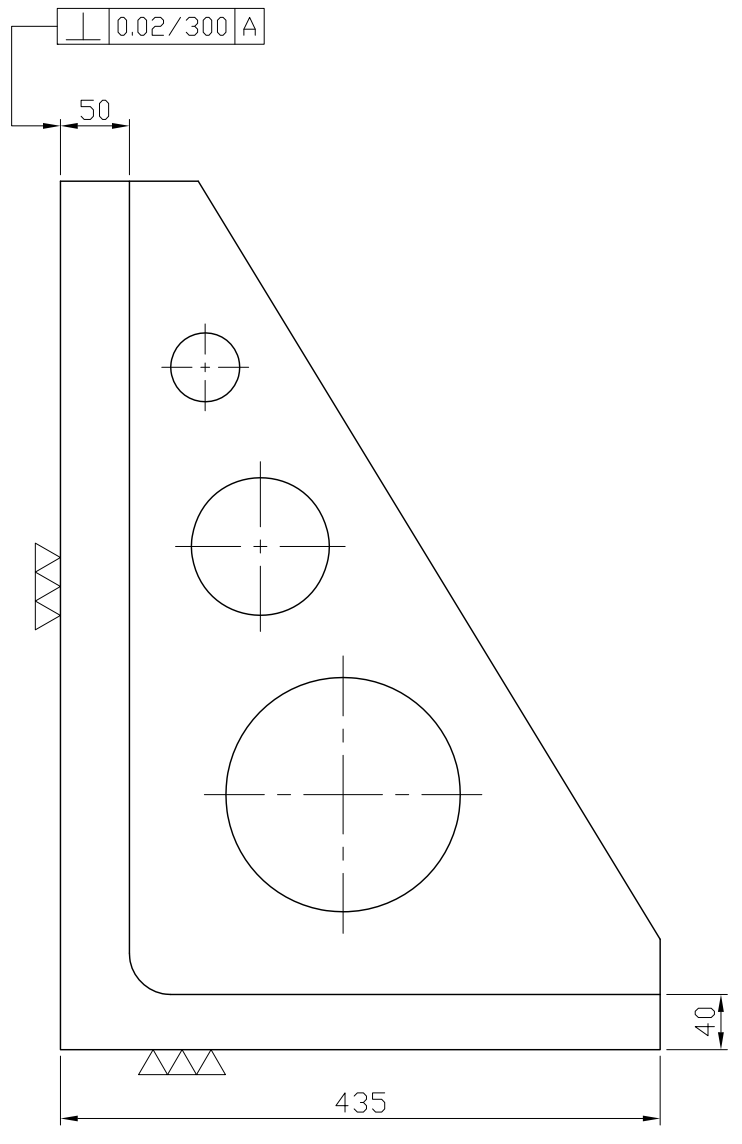
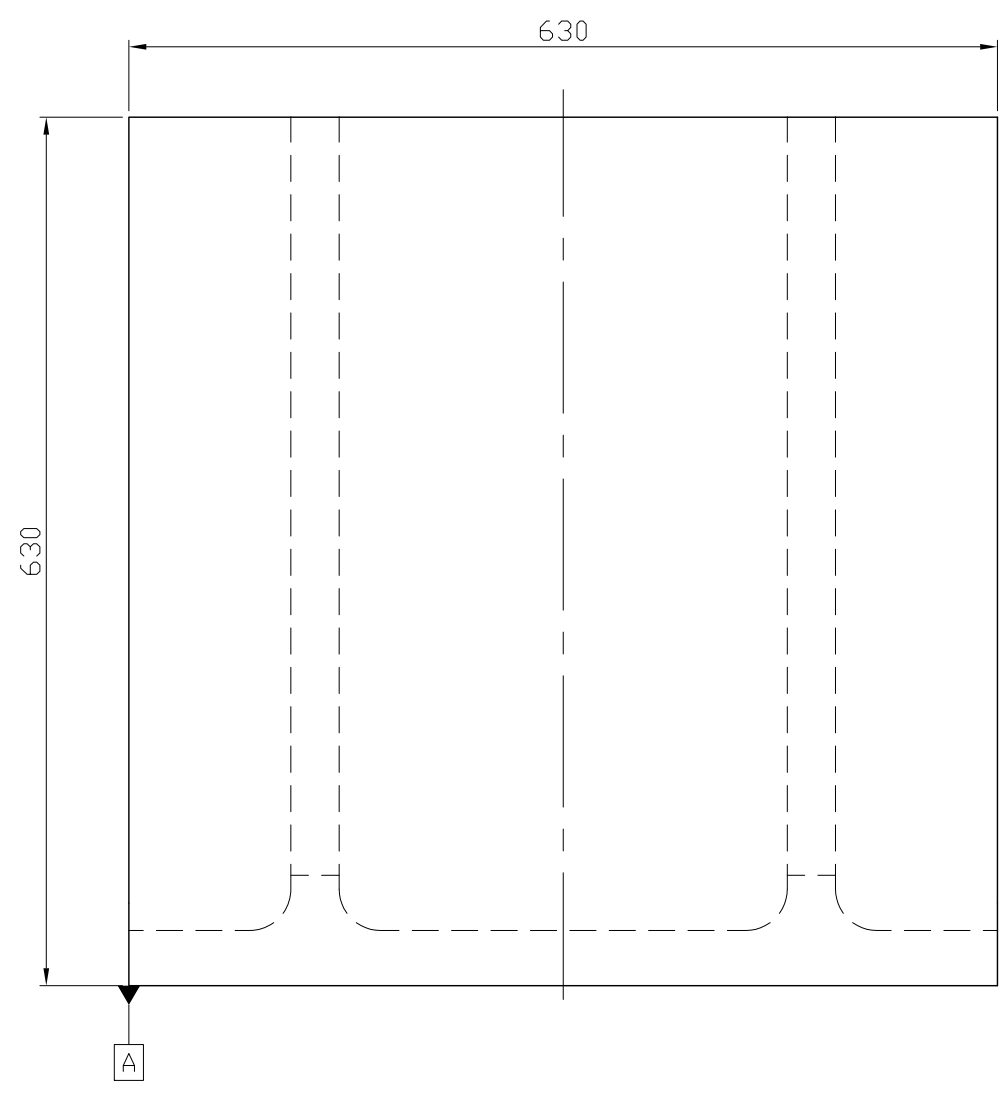
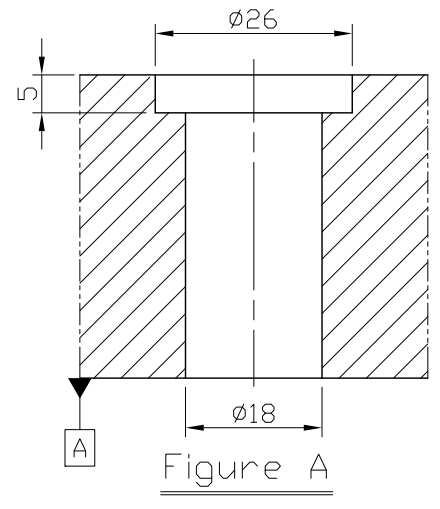
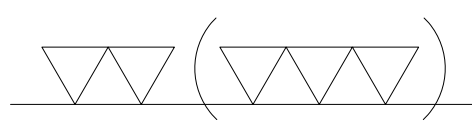

NW:275KG

*Edge chamfered C2

Material FC300		Heat treatment Annealing Process			Surface treatment			
Drafted by S.C.H	Checked by	Approved by	Scale 1/1	Date 2011.10.19	Sheet 1/1	Edition A		
			TITLE ANGLE PLATE					
			DWG.NO. BP20-435630-0630					